

# Research on the Calculation of Lightning Trip Flashover Rate for 10kV Distribution Line without Grounding Line

Tang Xiaoliang, Zeng Suiming, Yang Fang  
Qingyuan Power Supply Bureau of Guangdong Power Grid Company, Guangdong, China  
Email: yangfang118@163.com

Yang Zhining, Wu Xixiu\*  
Wuhan University of Technology, Hubei, China  
Email: wuxixiu@163.com

**Abstract**—For the reason that seldom research has been studied on the lightning trip flashover rate (LTFR) of distribution line, this paper focus on studying the calculation method about LTFR. The distribution line without mounting grounding line, flashover is mainly caused by direct stroke lightning and induced stroke lightning. Then, a conclusion can be drawn that LTFR is made up of direct stroke lightning trip rate and induced stroke lightning trip rate. Based on these, a model which can consider the structure of the distribution network, the type of grounding and lighting withstand level (LWL) is established. Furthermore, ATP-EMTP and the mirror method is applied to calculate the flashover probability caused by direct stroke lightning and the induced stroke lightning respectively. Moreover, to check the accuracy of the model, a typical 10kV distribution line in high lighting stroke area of China which is called Gaotian Line is chosen and the LTFR of the line is computed as well. The result shows that the computed result is very close to the practical running result, which proves the correctness of the model.

**Index Terms**—lightning trip flashover rate, grounding line, ATP-EMTP, mirror method, lighting withstand level, distribution network

## I. INTRODUCTION

The power distribution insulation level is very low, therefore it often suffers lighting strike, which seriously threaten the reliability of power system [1]. So, it's very important to improve the LWL of distribution network for insuring power reliability. Up to now, seldom research has been studied on LTFR of 10kV distribution line, Which results in the mechanism of LTFR can't be understood rightly and clearly. solve the problem, this paper focus on the calculation method of LTFR especially for the distribution line without mounting grounding line [2]. Research shows that, for distribution system without grounding line, direct stroke lightning and induced stroke lightning may cause insulator flashover and breaker tripping. Therefore, the model of

direct stroke lightning trip rate and induced stroke lightning trip rate have been established and ATP-EMTP and the mirror method is applied to calculate the flashover probability. Moreover, to check the accuracy of the model, a typical 10kV distribution line in high lighting stroke area of China which is called Gaotian Line is chosen and the LTFR of the line is computed as well. The result shows that the computed result is very close to the reality, which proves the correctness of the model.

## II. THE LTFR MODEL'S ESTABLISHMENT

For distribution system without grounding line, the trip out of breaker is mainly caused by direct stroke lightning and induced stroke lightning. Therefore, LTFR consists of direct stroke lightning trip rate  $n_1$  and induced stroke lightning trip rate  $n_2$ ,

$$n = n_1 + n_2 \quad (1)$$

$$n_1 = N \cdot p_1 \cdot [(P_{A,B} - P_{A,B,C}) + P_{A,B,C}(2-\eta)] \cdot \eta \quad (2)$$

$$n_2 = N \cdot p_2 \cdot [(P_{A,B} - P_{A,B,C}) + P_{A,B,C}(2-\eta)] \cdot \eta \quad (3)$$

where,  $N$  is flash collection rate, (flashes/100km/year).  $p_1$  is the probability of direct stroke lightning.  $p_2$  is the probability of striking on the floor, considering the structure of distribution network,  $p_1=p_2=0.5$ .  $P_{A,B}$ ,  $P_{A,B,C}$  are the probability of two-phase flashover and three-phase flashover caused by direct stroke lightning, respectively.  $P_{A,B}$ ,  $P_{A,B,C}$  are the probability of two-phase flashover and three-phase flashover caused by induced stroke lightning, respectively.  $\eta$  is arcing rate.

## III. CALCULATION OF KEY PARAMETERS

### A. Calculation of Probability of Direct Stroke Lightning Flashover

As shown in (2), the direct stroke lightning trip rate  $n_1$  depends on the value of  $P_{A,B}$ ,  $P_{A,B,C}$ . Then, to calculate these parameters, the model of 10kV distribution line suffered the direct stroke lightning is established and

ATP-EMTP is applied to calculate  $P_{A,B}$  and  $P_{A,B,C}$  [3], [4] (Fig. 1).

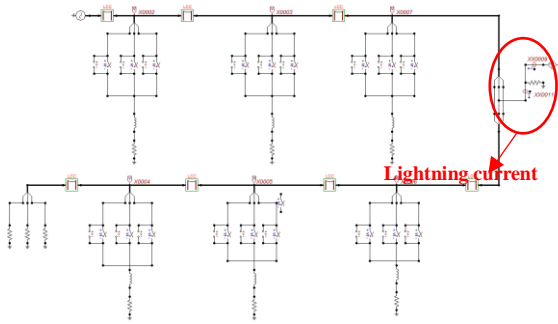

Figure 1. The model of 10kV distribution line suffered direct stroke lightning in ATP-EMTP.

It is very difficult and complicated to find out the value of LWL when the ATP-EMTP software is running. So, trial-and-error method is used to search the LWL. If the voltage of insulator becomes zero, flashover is occurring, the lightning current under this condition is just the LWL. And then,  $P_{A,B}$  and  $P_{A,B,C}$  can be obtained by using the probability statistics equation of lightning current exceeding LWL (Fig. 2-4).

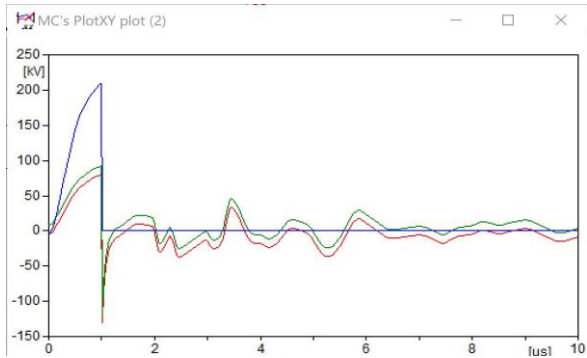

Figure 2. Simulation waveform of single-phase flashover under direct stroke lightning.

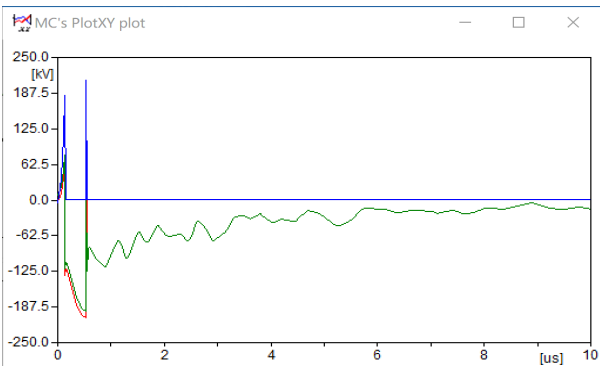

Figure 3. Simulation waveform of two-phase flashover under direct stroke lightning.

The flashover probability of direct stroke lightning in the mountainous areas of China can be expressed as,

$$\lg P = -\frac{I}{44} \quad (4)$$

Then, the flashover probability of two-phase or three-phase under the condition of direct stroke lightning can be written as,

$$P_{A,B} = 10^{\left(\frac{-I_d}{44}\right)} \quad (5)$$

$$P_{A,B,C} = 10^{\left(\frac{-I_t}{44}\right)} \quad (6)$$

where,  $I_d$ ,  $I_t$  are the LWL of two-phase flashover and three-phase flashover under direct stroke lightning, respectively.

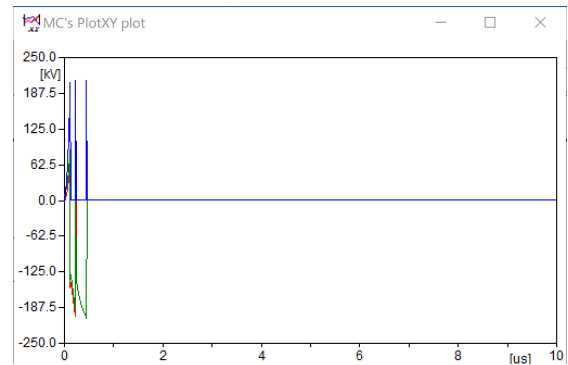

Figure 4. Simulation waveform of three-phase flashover under direct stroke lightning.

### B. Calculation of Flashover Probability of Induced Stroke Lightning

To calculate the probability of two-phase and three-phase flashover caused by induced stroke lightning. To get  $P'_{AB}$ , the induced overvoltage of insulators under induced stroke lightning condition must be calculated at first [5]-[7].

The flashover overvoltage of conductor caused by induced stroke lightning can be calculated by the following equations,

$$U'_{A,B} = \frac{U_{A,B}}{0.1h_{gt}} \quad (7)$$

$$U_{A,B} = \frac{U_{50\%}(Z_{AA} + 2R_i)}{Z_{AA}(1 - k_{AB})} \quad (8)$$

$$Z_{AA} = 60 \ln \frac{2h_A}{r_A} \quad (9)$$

where,  $h_{gt}$  is the height of the tower, (m).  $U_{50\%}$  is the flashover voltage of insulator, (kV).  $Z_{AA}$  is the surge impedance of phase A.  $R_i$  is the grounded resistance, ( $\Omega$ ).  $k_{AB}$  is the dimension coupling coefficient.  $r_A$  is the radius of conductor A, (cm).  $h_A$  is the height of the conductor A, (m).

Taking the height of the tower into consideration, the three-phase flashover overvoltage caused by induced stroke lightning can be calculated by function (10),

$$U'_{A,B,C} = \frac{U_{A,B,C}}{0.1h_{gt}} \quad (10)$$

where,  $U_{A,B,C}$  can be gotten using the following expression,

$$U_{A,B,C} = \frac{U_{50\%}(Z_{eq} + 2R_i)}{Z_{eq}(1 - k_{ABC})} \quad (11)$$

where,  $k_{ABC}$  is dimension coupling coefficient among three phase A, B and C.  $Z_{eq}$  is equivalent surge impedance.  $Z_{AB}$  is the mutual surge impedance between phase A and B.

The relationship between  $Z_{eq}$  and  $Z_{AA}$ ,  $Z_{AB}$  is shown as following,

$$Z_{eq} = (Z_{AA} + Z_{AB})/2 \quad (12)$$

Generally, for multi-conductor transmission line, mirror method is used to solve the surge impedance, such as the calculation of  $Z_{AB}$ , which is shown in Fig. 5.

$$Z_{AB} = \ln \frac{d'_{AB}}{d_{AB}} \quad (13)$$

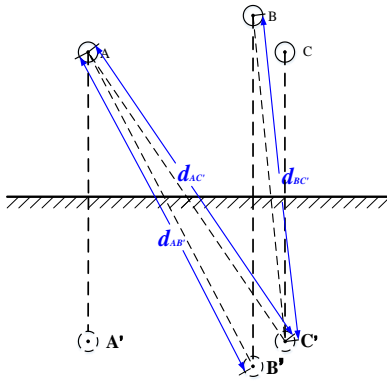

Figure 5. The mirror point of three phase distribution line.

As shown in Fig. 5, point A, B, C represents phase A, B and C of 10kV distribution line, respectively. And A', B' and C' are the corresponding mirror point of A, B, C.  $d_{XY}$  is the distance between point X and point Y.

$$k_{ABC} = \frac{Z_{AC} + Z_{BC}}{Z_{AA} + Z_{AB}} = \frac{\ln \frac{d_{AC'}}{d_{AC}} + \ln \frac{d_{BC'}}{d_{BC}}}{\ln \frac{2h_A}{r_A} + \ln \frac{d_{AB'}}{d_{AB}}} \quad (14)$$

According to the mirror method,  $d_{AC'}$ ,  $d_{BC'}$ ,  $d_{AB'}$  can be expressed as,

$$d_{AC'} = \sqrt{(2h_A)^2 + (d_{AC})^2} \quad (15)$$

$$d_{BC'} = \sqrt{(h_B + h_C)^2 + (d_{BC})^2} \quad (16)$$

$$d_{AB'} = \sqrt{(h_A + h_B)^2 + (d_{AB})^2} \quad (17)$$

where,  $h_A$ ,  $h_B$ ,  $h_C$  are the height of the conductor A, B, C, respectively, (m). The value of  $P'_{A,B}$  and  $P'_{A,B,C}$  can be

easily obtained when the  $U'_{A,B}$  and  $U'_{A,B,C}$  is calculated [8].

### C. Calculation of Lightning Strike Probability

Lightning strike probability can be expressed as,

$$N = 0.1 \cdot N_g (b + 4h_{gt}) \quad (18)$$

where,  $N_g$  is ground flash density, (times/km<sup>2</sup> a),  $b$  is the distance between two grounding lines, (m). For the distribution line without grounding line,  $b$  equals zero,  $b=0$ .

### D. Calculation of Ground Flash Density

According to IEEE guide for improving the lightning performance of electric power overhead distribution lines (IEEE Std 1410™-2010), ground flash density  $N_g$  can be gotten using the following equation,

$$N_g = 0.04T_d^{1.25} \quad (19)$$

where,  $T_d$  is the number of days with thunder per year.

### E. Calculation of Arcing Rate

For Chinese distribution system belonging to underground system, arcing rate depends on the ionization degree of arc channel, the length of arc channel and system voltage, which can be written as,

$$\eta = (1.6 \cdot \frac{U_N}{l_{dis}}) \cdot 10^{-2} = (1.6 \cdot \frac{U_N}{2(D+l)}) \cdot 10^{-2} \quad (20)$$

where,  $\eta$  is the probability of stable arc after two-phase flashover, the arcing rate.  $U_N$  is the voltage of system, (kV).  $l_{dis}$  is the length of discharge path when two-phase flashover, (m).  $D$  is the length of insulator, (m).  $l$  is the diameter of insulator, (m).

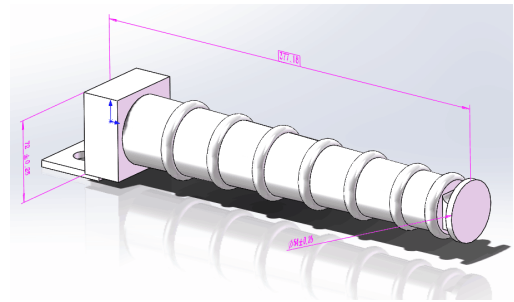

Figure 6. The insulator used in 10kV distribution line.

Fig. 6 is the schematic diagram of the insulator which is often used in 10kV distribution line, and the creep age distance of the insulator is obtained,

$$l_{dis} = 2(D+l) \quad (21)$$

## IV. CALCULATION OF LTFR OF DISTRIBUTION LINE IN A HIGH THUNDERSTORM REGION

### A. Parameter of 10kV Distribution Network of A High Thunderstorm Region

To check the correctness of model, Gaotian Line in Qingyuan is chosen to calculate the LTFR (Table I).

TABLE I. PARAMETERS OF 10KV DISTRIBUTION LINE OF GAOTIAN LINE

P	$h_A$	$h_B$	$h_C$	$r_A$	$D$	$l$	$U_{50\%}$	$R_i$	$U_N$
V	9.2	10	9.2	0.0075	0.377	0.06	210	20	10

Note,  $P$  denotes parameters,  $V$  denotes the value of parameters. The unite of the parameters are  $m$ , except  $U_{50\%}$ ,  $U_N$ ,  $R_i$  which the unites are  $kV$  and  $\Omega$ , respectively.

B. Calculation of LTFR

Based on the above working, the parameters of (2) and (3) can be obtained which are listed in Table II.

TABLE II. THE PARAMETERS OF TRIP OUT MODEL

P	$P_{A,B}$	$P_{A,B,C}$	$P'_{A,B}$	$P'_{A,B,C}$	$\eta$
V	0.452	0.297	0.7	0.3	0.183

Using the date of Table II, the LTFR can be easily get,

$$n_1 = N \cdot p_1 \cdot [(P_{A,B} - P_{A,B,C}) + P_{A,B,C}(2 - \eta)] \cdot \eta$$

$$= 0.1 \cdot 0.04 \cdot T_d^{1.25} \cdot 40 \cdot 0.5 \cdot [(0.452 - 0.297) + 0.297(2 - 0.183)] \cdot 0.183$$

$$= 1.02 \times 10^{-2} T_d^{1.25}$$

$$n_2 = N \cdot p_2 \cdot [(P'_{A,B} - P'_{A,B,C}) + P'_{A,B,C}(2 - \eta)] \cdot \eta$$

$$= 0.1 \cdot 0.04 \cdot 120^{1.25} \cdot 40 \cdot 0.5 \cdot [(0.7 - 0.3) + 0.3(2 - 0.183)] \cdot 0.183$$

$$= 1.38 \times 10^{-2} T_d^{1.25}$$

Consequently, the total LTFR is,

$$n = n_1 + n_2 = 2.4 \times 10^{-2} T_d^{1.25}$$

After a series computing process, we get the mathematical expression between the thunder days and the trip out, as shown in (22), (23), (24), respectively.

Using the mathematical equation, the LTFR of Qingyuan under different thunder days is calculated, which is shown in Table III.

TABLE III. THE RELATIONSHIP BETWEEN THE LTFR AND THE THUNDER DAYS

$T_d$	80	120	160	200	240
$n_1$	2.440	4.051	5.804	7.672	9.635
$n_2$	3.302	5.481	7.853	10.379	13.036
$n$	5.742	9.532	13.657	18.051	22.671
$n_1/n$	42.494%	42.499%	42.498%	42.502%	42.499%
$n_2/n$	57.506%	57.501%	57.502%	57.498%	57.501%

C. Analysis of Influence Factors

The fitting relationship between the thunder days and the LTFR from-Table III, is shown in Fig. 7-9.

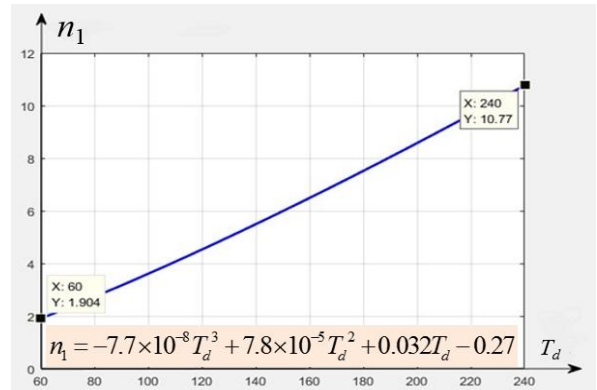

Figure 7. Relationship between thunder days and the direct stroke lightning trip rate.

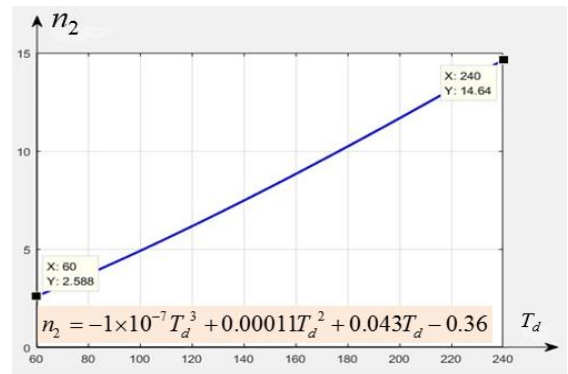

Figure 8. Relationship between thunder days and the induced stroke lightning trip rate.

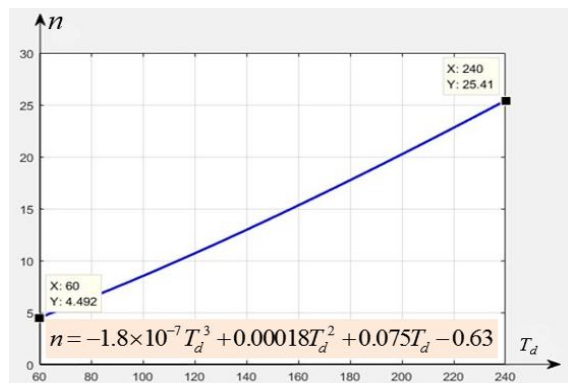

Figure 9. Relationship between thunder days and the total LTFR.

Under the condition of direct stroke lightning, the function between direct stroke lightning rate  $n_1$  and the thunder days  $T_d$  can be written as,

$$n_1 = -7.7 \times 10^{-8} T_d^3 + 7.8 \times 10^{-5} T_d^2 + 0.032 T_d - 0.27 \quad (25)$$

Under the condition of induced stroke lightning, we can get the fitting curve expression between induced stroke lightning rate  $n_2$  and the thunder days  $T_d$  expresses as function (26),

$$n_2 = -1 \times 10^{-7} T_d^3 + 7.8 \times 0.00011 T_d^2 + 0.043 T_d - 0.36 \quad (26)$$

According to the relationship curve in Fig. 9, the expression between stroke lightning rate  $n$  and thunder days  $T_d$  can be written as,

$$n = -1.8 \times 10^{-7} T_d^3 + 0.00018 T_d^2 + 0.075 T_d - 0.63 \quad (27)$$

From the curves and the equations above, a conclusion can be drawn that, the LTFR is in direct proportion to the thunder days, that is, the more days of thunder, the higher the LTFR.

In addition, changing the value of LWL, the relationship curve between the LWL and the LTFR can be drawn as Fig. 10-13.

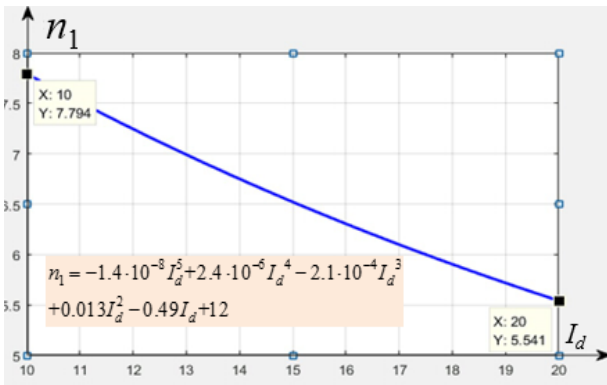

Figure 10. Relationship between the direct stroke lightning trip rate and the LWL of two-phase flashover.

The expression between the direct stroke lightning rate  $n_1$  and the LWL of two-phase flashover  $I_d$  can be written as,

$$n_1 = -1.4 \times 10^{-8} I_d^5 + 2.4 \times 10^{-6} I_d^4 - 2.1 \times 10^{-4} I_d^3 + 0.013 I_d^2 - 0.49 I_d + 12 \quad (28)$$

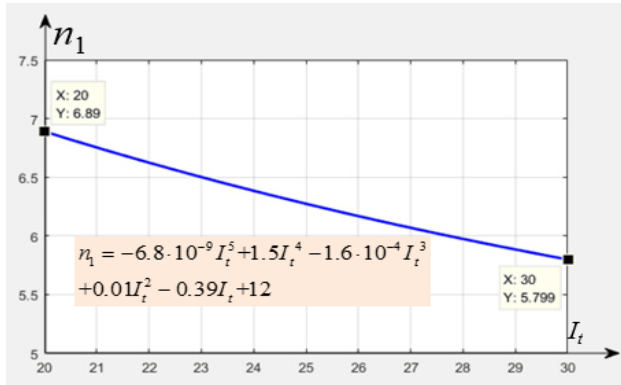

Figure 11. Relationship between the direct stroke lightning trip rate and the LWL of three-phase flashover.

The value of the direct stroke lightning rate  $n_1$  decreases with the increasing of the LWL of three-phase flashover  $I_t$ ,

$$n_1 = -6.8 \times 10^{-9} I_t^5 + 1.5 I_t^4 - 1.6 \times 10^{-4} I_t^3 + 0.01 I_t^2 - 0.39 I_t + 12 \quad (29)$$

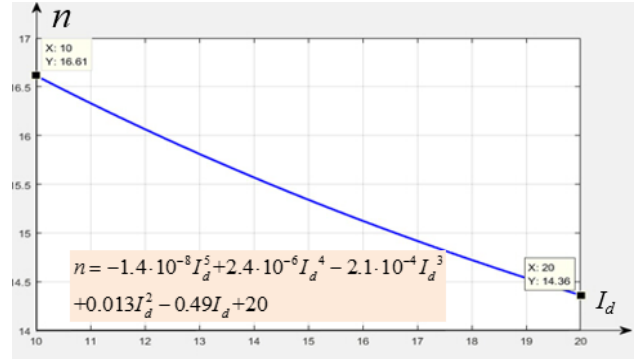

Figure 12. Relationship between the total LTFR and the LWL of two-phase flashover.

According to the relationship curve in Fig. 12, the stroke lightning rate  $n$  can be expressed by the LWL of two-phase flashover  $I_d$  as (30),

$$n = -1.4 \times 10^{-8} I_d^5 + 2.4 \times 10^{-6} I_d^4 - 2.1 \times 10^{-4} I_d^3 + 0.013 I_d^2 - 0.49 I_d + 20 \quad (30)$$

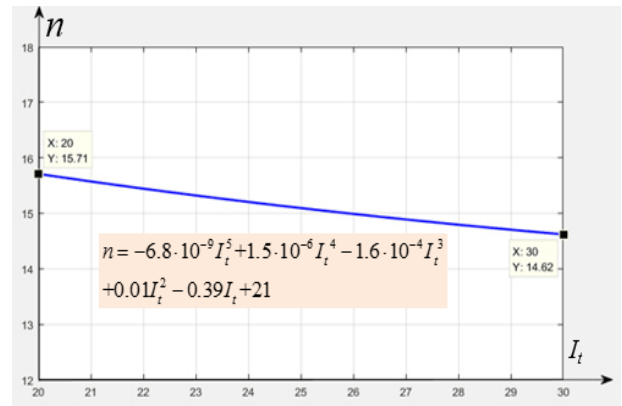

Figure 13. Relationship between the total LTFR and the LWL of three-phase flashover

The mathematic function (31) is used to express the relationship between the stroke lightning rate  $n$  and the LWL of three-phase flashover  $I_t$ ,

$$n = -6.8 \times 10^{-9} I_t^5 + 1.5 \times 10^{-6} I_t^4 - 1.6 \times 10^{-4} I_t^3 + 0.01 I_t^2 - 0.39 I_t + 21 \quad (31)$$

From Fig. 10-13, a conclusion can be drawn from the relationship curves that the LTFR is in negative correlation with the LWL. Especially, compared with the LWL of three-phase flashover, the LWL of two-phase flashover has a greater influence on the LTFR.

## V. CONCLUSION

For 10kV power distribution line without mounting grounding line, the LTFR caused by induced stroke lightning is higher than that of direct stroke lightning.

The model reveals that the LTFR cause by direct stroke lightning depending on the LWL. While for the induced stroke lightning, the LWL has no influence on the LTFR which mainly relies on the flashover voltage.

Many factors have significant influence on the LTFR. Among them, the thunder days has the greatest effect on LTFR. The LTFR increases abruptly with the increasing of thunder days.

The LWL has great influence on  $n_1$ , while it almost has no influence on  $n_2$ .

The LTFR decrease with increasing of LWL under the condition of direct stroke lightning. Compared with the LWL of three-phase flashover, the LWL of two-phase flashover has a greater influence on the LTFR.

#### REFERENCES

[1] A. Jiang, P. Nie, J. Yang, et al. "Design and evaluation of differentiated lightning protection countermeasures for Pu Dong 10 kV distribution lines," in *Proc. 2016 China International Conference on Electricity Distribution (CICED 2016)*, Xi'an, 2016, pp. 1-5.

[2] W. Jin, W. Wang, "Differentiated lightning protection method for 10 kV distribution grid," in *Proc. 2012 China International Conference on Electricity Distribution (CICED 2012)*, Shanghai, 2012, pp. 1-4.

[3] J. A. Martinez-Velazco F C. "Lightning performance analysis of overhead transmission lines using the EMTP," *IEEE Transactions on Power Delivery*, vol. 3, no. 20, 2005, pp. 2200-2210.

[4] M. S. Rahimian, A. M. Hussein, "ATP modelling of the lightning current within a tall structure and the attached channel," in *Proc. 2012 International Conference on Lightning Protection (ICLP)*, Vienna, Austria, 2012, pp. 1-5.

[5] Z. Lu, S. Gu, C. Zhao, "Calculation of lightning trip-out rates for 10 kV overhead distribution line," in *Proc. 2014 International Conference on Lightning Protection (ICLP)*, Shanghai, China, 2014, pp. 667-670.

[6] T. Sun, H. Liu, Y. L. Qi, H. Li, W. J. Zhou, J. H. Yu, "Lightning trip-out risk evaluation of a 220kV transmission line in Shiyan," in *Proc. 2014 International Conference on Lightning Protection (ICLP)*, Shanghai, China, 2014, pp. 1508-1511.

[7] G. D. Gao, H. F. Wang, L. T. Huang, S. F. Zhao, "The calculation model of the shielding failure trip-out rate of double-circuit transmission line on the same tower," in *Proc. 2012 Power Engineering and Automation Conference*, Wuhan, China, 2012, pp. 1-5.

[8] Transmission and Distribution Committee, *IEEE Guide Improving the Lightning Performance of Electric Power Overhead Distribution Lines*, USA: New York, 2011.



**Tang Xiaoliang** was born in Hubei Province, China, in 1984. He received the M.E. degree from Jilin University, Jilin, China. At present, he is working as an engineer in Qingyuan Power Supply Bureau of Guangdong Power Grid Company, and his research interests include transmission and distribution.



**Yang Zhining** was born in Liaoning Province, China, in 1994. She received the B.E. degree in electrical engineering from Wuhan University of Technology, Wuhan, China. At current, she is candidate of the M.E. degree in high voltage and insulation technology. She is very interesting in distribution line, especially lightning protect and grounding.